

**ATTENTION:**  
THE FOLLOWING DIMENSIONS AND WEIGHTS  
**DO NOT INCLUDE THE PACKAGING**

LEGEND	
HPG	High pressure gauge ( Opt )
LPG	Low pressure gauge
MW	Water pressure gauge
RM	Manual water filling cap
VSC	Water drain valve
SFAF	Free cooling manual air vent
VSCF	Free cooling water drain valve
PD	Display cover protection
ATV	Rubber type antivibrant mounting ( Opt )

**LIFTING AND CARRIAGE PRECAUTIONS**

- Check the weight on the CE label to select appropriate lift equipment .
- Before lifting the unit make sure that the external panel is firmly fixed in place.
- To use only lifting points provided.
- The chains or slings must be of equal length.
- To use a spread-bar to avoid damage to the unit.
- The movement must be performed with caution and avoid abrupt movements.
- Never move the unit on rollers.

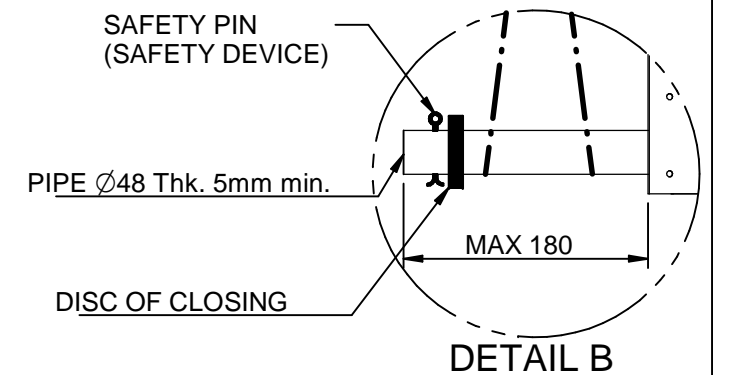
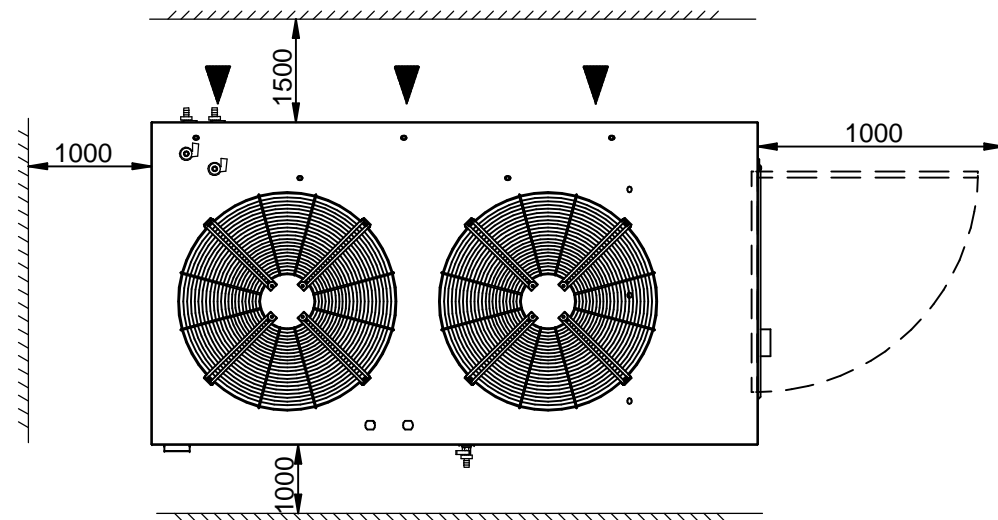

MOD.	EMPTY WEIGHT	OPERATING WEIGHT	HYDRAULIC CONNECTIONS
ENRF.022	460 kg	745 kg	1" 1/2 BSP F
ENRF.030	470 kg	755 kg	1" 1/2 BSP F

Scala-Scale	Data-Date	09/06/14	Dis.to-Drawn	M. M.	N°Pezzi
Peso-Weight Kg.	Materiali-Materials				
Denominazione-Denomination					
WATER CHILLERS mod. ENRF.022÷030					
Particolare-Detail					
Overall dimension - Lift Instruction					
REFRIGERANT R410A / R32 / R454B					

<b>HITEMA®</b>	
DIS.-DRAW N.	DIM-ENRF-022ST01
Rev.	04-M.M.-05/05/20
PROGRAM.N.	