

**LEGEND**

HPG	High pressure gauge
LPG	Low pressure gauge
MW	Water pressure gauge
RM	Manual water filling cap
VSC	Water drain valve
SFAF	Free cooling manual air vent
VSCF	Free cooling water drain valve
ATS	Spring type antivibrant mounting ( Opt )
ATV	Rubber type antivibrant mounting ( Opt )

**LIFTING AND CARRIAGE PRECAUTIONS**

- Check the weight on the CE label to select appropriate lift equipment .
- Before lifting the unit make sure that the external panel is firmly fixed in place.
- To use only lifting points provided.
- The chains or slings must be of equal length.
- To use a spread-bar to avoid damage to the unit.
- The movement must be performed with caution and avoid abrupt movements.
- Never move the unit on rollers.
- Never lift the unit using a fork-lift.

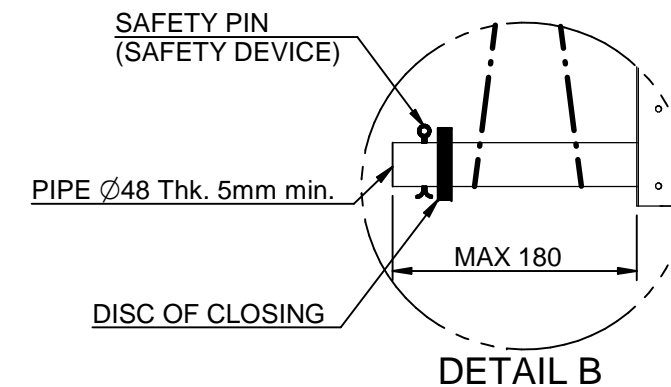
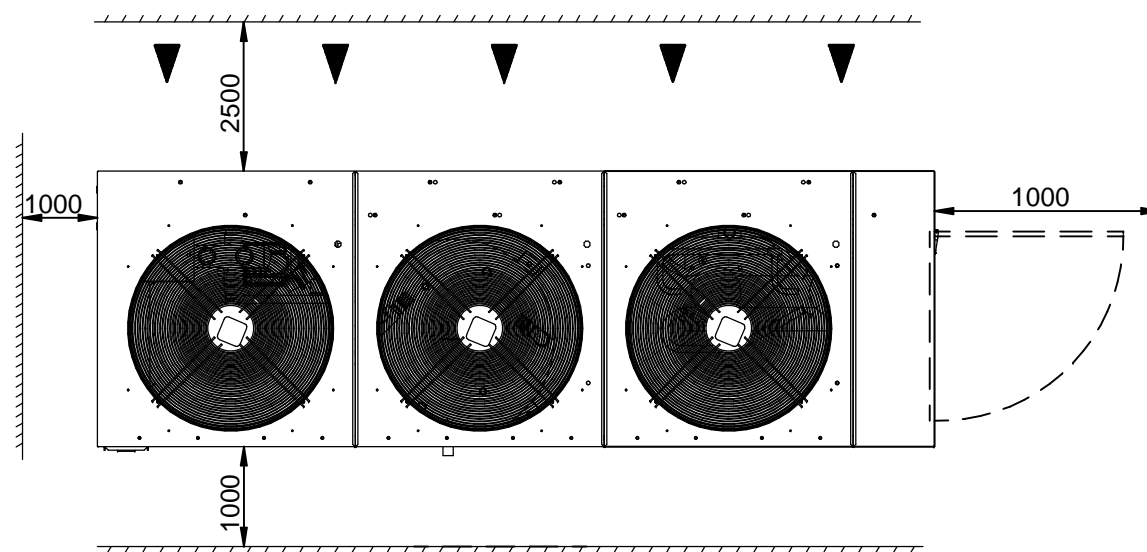

MOD.	EMPTY WEIGHT	OPERATING WEIGHT	N° FANS
ENRF.061	1120 kg	1590 kg	2
ENRF.070	1125 kg	1595 kg	2
ENRF.075	1150 kg	1620 kg	2
ENRF.090	1180 kg	1650 kg	3

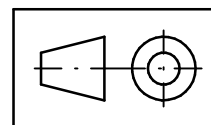
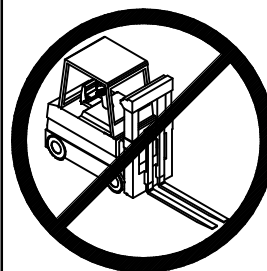

Scala-Scale	Data-Date	Dis.to-Drawn	N°Pezzi
	30/09/13	B.C.	
Peso-Weight Kg.	Materiali-Materials		
Denominazione-Denomination			
WATER CHILLERS mod. ENRF.061÷090/T.WP.			
Particolare-Detail			
Overall dimension - Lift Instruction			
REFRIGERANT R410a			



DIS.-DRAW N.	DIM-ENRF-061ST01
Rev.	05 - B.C. - 30/04/20
PROGRAM.N.	