

LEGEND

HPG	High pressure gauge
LPG	Low pressure gauge
MW	Water pressure gauge
RM	Manual water filling cap
VSC	Water drain valve
SFAF	Free cooling manual air vent
VSCF	Free cooling water drain valve
PD	Display cover protection
ATV	Rubber type antivibrant mounting (Opt)

LIFTING AND CARRIAGE PRECAUTIONS

- Check the weight on the CE label to select appropriate lift equipment .
- Before lifting the unit make sure that the external panel is firmly fixed in place.
- To use only lifting points provided.
- The chains or slings must be of equal length.
- To use a spread-bar to avoid damage to the unit.
- The movement must be performed with caution and avoid abrupt movements.
- Never move the unit on rollers.

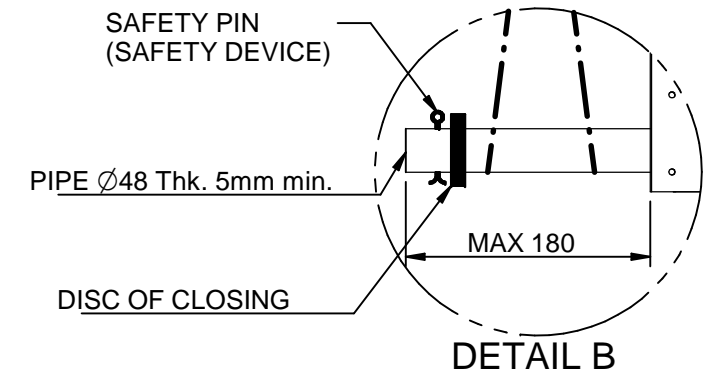
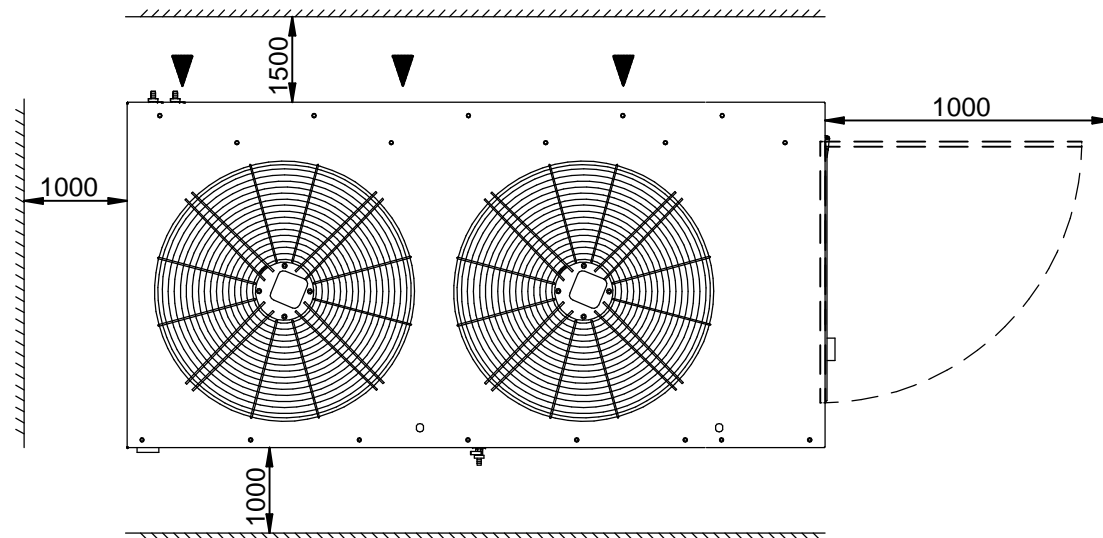

MOD.	EMPTY WEIGHT	OPERATING WEIGHT
ENRF.038	635 kg	930 kg
ENRF.045	650 kg	950 kg
ENRF.055	740 kg	1035 kg

Scala-Scale	Data-Date	Dis.to-Drawn	N°Pezzi
	29/04/14	M. M.	
Peso-Weight Kg.	Materiali-Materials		
Denominazione-Denomination			
WATER CHILLERS mod. ENRF.038÷055			
Particolare-Detail			
Overall dimension - Lift Instruction			
REFRIGERANT R410a			

HITEMA®

DIS.-DRAW N.	DIM-ENRF-038ST01
Rev.	03-M.M.-14/10/19
PROGRAM.N.	